



basic education

Department:
Basic Education
REPUBLIC OF SOUTH AFRICA

**NATIONAL
SENIOR CERTIFICATE**

GRADE 12

PHYSICAL SCIENCES: CHEMISTRY (P2)

EXEMPLAR 2014

MARKS: 150

TIME: 3 hours

This question paper consists of 15 pages and 4 data sheets.

INSTRUCTIONS AND INFORMATION

1. Write your name in the appropriate space on the ANSWER BOOK.
2. This question paper consists of TEN questions. Answer ALL the questions in the ANSWER BOOK.
3. Start EACH question on a NEW page in the ANSWER BOOK.
4. Number the answers correctly according to the numbering system used in this question paper.
5. Leave ONE line between two subquestions, for example between QUESTION 2.1 and QUESTION 2.2.
6. You may use a non-programmable calculator.
7. You may use appropriate mathematical instruments.
8. You are advised to use the attached DATA SHEETS.
9. Show ALL formulae and substitutions in ALL calculations.
10. Round off your final numerical answers to a minimum of TWO decimal places.
11. Give brief motivations, discussions, et cetera where required.
12. Write neatly and legibly.

QUESTION 1: MULTIPLE-CHOICE QUESTIONS

Four options are provided as possible answers to the following questions. Each question has only ONE correct answer. Write only the letter (A–D) next to the question number (1.1–1.10) in the ANSWER BOOK, for example 1.11 E.

- 1.1 The primary nutrient needed by plants for the promotion of root growth is ...
- A nitrogen.
 - B phosphorus.
 - C potassium.
 - D calcium. (2)
- 1.2 The rate of a chemical reaction can be expressed in ...
- A grams per mole.
 - B energy consumed per mole.
 - C volume of gas formed per unit time.
 - D moles of product formed per litre of solution. (2)
- 1.3 Which ONE of the compounds below is an aldehyde?
- A CH_3CHO
 - B CH_3COCH_3
 - C CH_3COOH
 - D CH_3OH (2)
- 1.4 The reaction represented by the equation below takes place in the presence of a catalyst.
- $$\text{C}_{13}\text{H}_{28}(\ell) \rightarrow \text{C}_2\text{H}_4(\text{g}) + \text{C}_3\text{H}_6(\text{g}) + \text{C}_8\text{H}_{18}(\ell)$$
- This reaction is an example of ...
- A addition.
 - B cracking.
 - C substitution.
 - D polymerisation. (2)

1.5 Which ONE of the following graphs shows the relationship between activation energy (E_a) of a reaction and temperature?

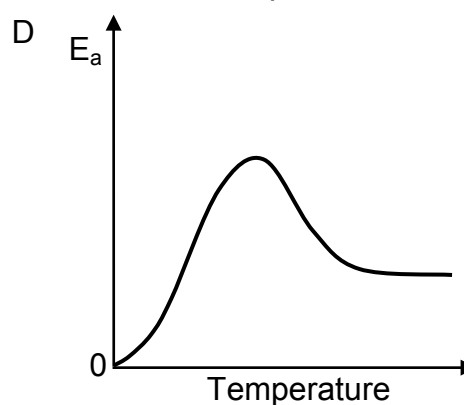
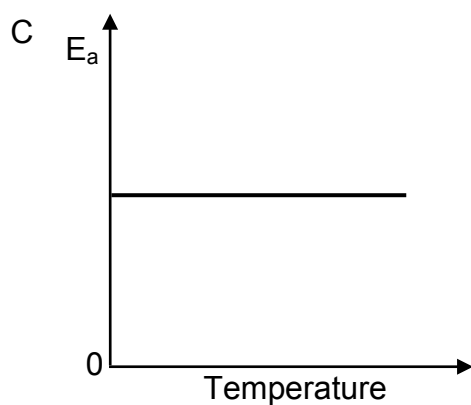
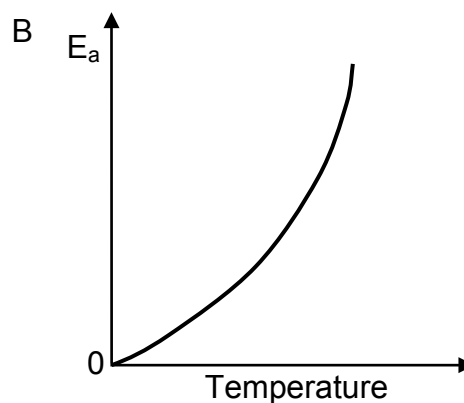
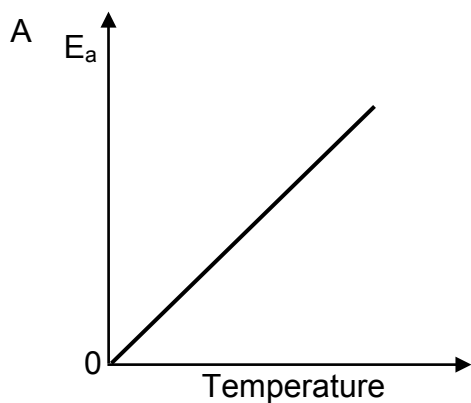

(2)

1.6 Which ONE of the following CANNOT act as a reducing agent?



(2)

1.7 Consider the structural formula of an organic compound below.

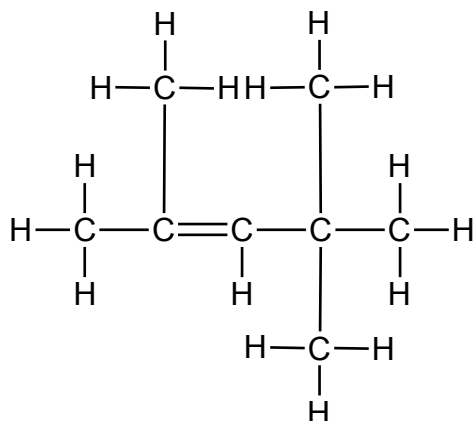

Which ONE of the following is the correct IUPAC name of this compound?

- A 2,2,4-trimethylpent-2-ene
- B 2,2,4-trimethylpent-3-ene
- C 2,4,4-trimethylpent-2-ene
- D 2,4,4-trimethylpent-3-ene (2)

1.8 A sample of silver contains impurities of gold. During purification by electrolysis, the impure silver is used as an electrode.

Which ONE of the following is the best choice of anode and cathode for this process?

	CATHODE	ANODE
A	Pure gold	Impure silver
B	Impure silver	Pure gold
C	Pure silver	Impure silver
D	Impure silver	Pure silver

(2)

- 1.9 Initially, a certain amount of ICl(g) is sealed in an empty flask at a certain temperature. The reaction that takes place is:

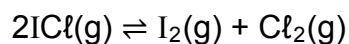

Which of the following statements describe(s) the change(s) occurring as the system proceeds towards equilibrium?

- (i) The rate of the reverse reaction increases.
- (ii) The concentration of ICl(g) increases.
- (iii) The concentration of $\text{Cl}_2\text{(g)}$ increases.

A (i) only

B (ii) only

C (i) and (iii) only

D (ii) and (iii) only

(2)

- 1.10 Consider the reaction represented by the equation below.



The strongest base in the above reaction is:

A H_2PO_4^-

B HCO_3^-

C H_3PO_4

D H_2CO_3

(2)
[20]

QUESTION 2 (Start on a new page.)

The letters **A** to **G** in the table below represent seven organic compounds.

A		B	
C		D	
E	Butane	F	
G	Ethyl propanoate		

2.1 Write down the:

- 2.1.1 Name of the homologous series to which compound **F** belongs (1)
- 2.1.2 Name of the functional group of compound **D** (1)
- 2.1.3 Letter that represents a primary alcohol (1)
- 2.1.4 IUPAC name of compound **A** (2)
- 2.1.5 Structural formula of the monomer of compound **B** (2)
- 2.1.6 Balanced equation, using molecular formulae, for the combustion of compound **E** in excess oxygen (3)

2.2 Briefly explain why compounds **C** and **D** are classified as POSITIONAL ISOMERS. (2)

2.3 Compound **G** is prepared using an alcohol as one of the reactants. Write down the balanced equation for the reaction using structural formulae for all the organic reagents. (7)

[19]

QUESTION 3 (Start on a new page.)

The table below shows the results obtained from experiments to determine the boiling point of some alkanes and alcohols of comparable molecular masses.

Compound	Relative molecular mass	Boiling point (°C)
CH ₃ CH ₃	30	-89
CH ₃ OH	32	65
CH ₃ CH ₂ CH ₃	44	-42
CH ₃ CH ₂ OH	46	78
CH ₃ CH ₂ CH ₂ CH ₃	58	0
CH ₃ CH ₂ CH ₂ OH	60	97
CH ₃ CH ₂ CH ₂ CH ₂ CH ₃	72	36
CH ₃ CH ₂ CH ₂ CH ₂ CH ₂ OH	74	117

- 3.1 Define the term *boiling point*. (2)
- 3.2 Consider the boiling points of the four alkanes in the above table.
- 3.2.1 Describe the trend in their boiling points. (1)
- 3.2.2 Fully explain the trend in QUESTION 3.2.1. (3)
- 3.3 The boiling point of each alcohol is much higher than that of the alkane of comparable relative molecular mass. Explain this observation by referring to the type and strength of the intermolecular forces in alkanes and alcohols. (2)

[8]

QUESTION 4 (Start on a new page.)

The flow diagram below shows the preparation of different organic compounds using $\text{CH}_3\text{CH}=\text{CH}_2$ as starting material. **X**, **Y**, **Z** and **P** represent different organic reactions.

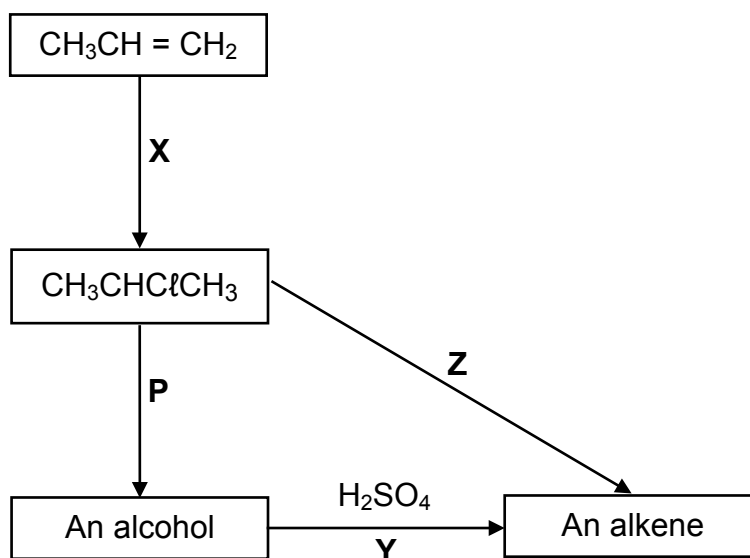

- 4.1 To which homologous series does $\text{CH}_3\text{CH}=\text{CH}_2$ belong? (1)
- 4.2 Write down the:
- 4.2.1 Type of reaction of which **X** is an example (1)
- 4.2.2 Structural formula and IUPAC name of the alcohol produced during reaction **P** (3)
- 4.2.3 Type of reaction of which **Y** is an example (1)
- 4.2.4 Function of the acid in reaction **Y** (1)
- 4.3 For reaction **Z**, write down:
- 4.3.1 The NAME of the inorganic reagent needed (1)
- 4.3.2 TWO reaction conditions needed (2)
- 4.3.3 A balanced equation for the production of the alkene, using structural formulae (5)
- [15]**

QUESTION 5 (Start on a new page.)

Zinc granules are added to 100 cm³ of a 0,2 mol·dm⁻³ hydrochloric acid solution in an Erlenmeyer flask. The equation for the reaction that takes place is:

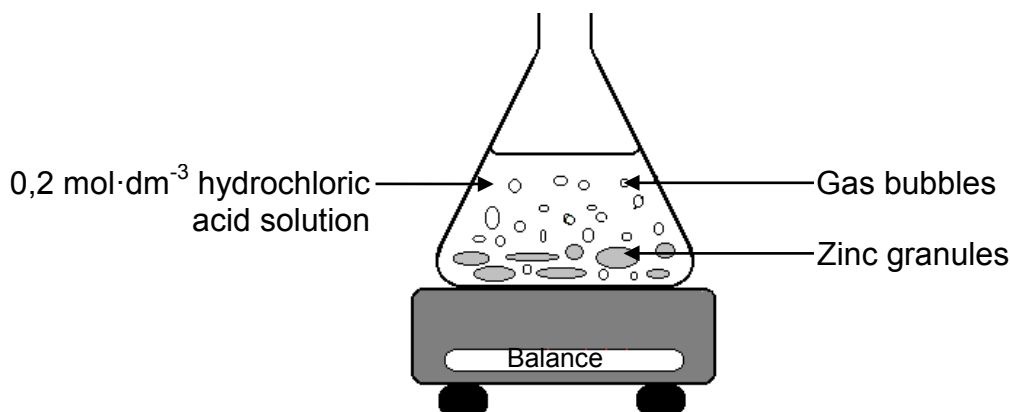
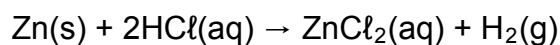

The rate of the reaction is followed by measuring the loss in mass of the flask and its contents at regular time intervals. After completion of the reaction, it is found that 0,12 g zinc granules did not react.

- 5.1 Which reactant is the limiting reagent? (1)
- 5.2 Give a reason for the loss in mass of the flask and its contents. (1)
- 5.3 Sketch a graph of the mass of zinc versus time for the above reaction. Label this graph **P**. (2)
- 5.4 On the same set of axes as in QUESTION 5.3, sketch graph **Q** which represents the same reaction at a HIGHER TEMPERATURE. (1)
- 5.5 Use the collision theory to explain why graph **Q** differs from graph **P**. (2)
- 5.6 Calculate the mass of zinc initially present in the flask. (6)
- [13]**

QUESTION 6 (Start on a new page.)

A sample of N_2O_4 gas is sealed in a container and heated. The N_2O_4 gas decomposes to NO_2 gas and the reaction reaches equilibrium according to the following balanced equation:

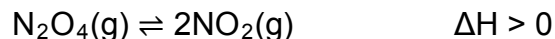

The graph below shows how the concentrations of the two gases change as a result of changes made to the reaction conditions.

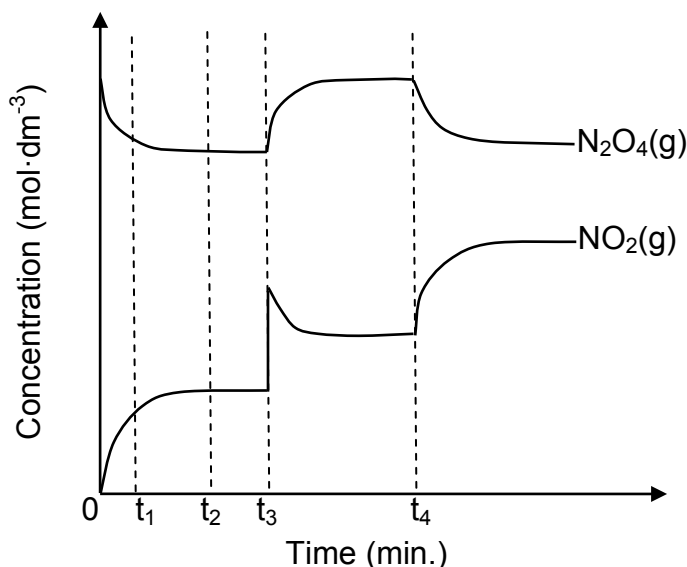

- 6.1 Define the term *chemical equilibrium*. (2)
- 6.2 How does the rate of the forward reaction compare to that of the reverse reaction at each of the following times? Only write down HIGHER THAN, LOWER THAN or EQUAL TO.
- 6.2.1 t_1 (1)
- 6.2.2 t_2 (1)
- 6.3 What change was made to the reaction conditions at each of the following times? In both instances, the equilibrium constant for the reaction did not change.
- 6.3.1 t_3 (1)
- 6.3.2 t_4 (1)
- 6.4 How will an increase in temperature influence the yield of $\text{NO}_2(\text{g})$? Write down INCREASES, DECREASES or REMAINS THE SAME. Use Le Chatelier's principle to explain the answer. (3)
- 6.5 Initially 0,92 mol N_2O_4 gas is sealed in a 2 dm^3 container and heated to $100 \text{ }^\circ\text{C}$. At equilibrium it is found that 20,7% of the N_2O_4 gas has decomposed to NO_2 gas. Calculate the equilibrium constant (K_c) for this reaction at $100 \text{ }^\circ\text{C}$. (7)

[16]

QUESTION 7 (Start on a new page.)

A Grade 12 class wants to determine the percentage of ethanoic acid in a certain bottle of vinegar. They titrate a sample taken from the bottle of vinegar with a standard solution of sodium hydroxide. The equation for the reaction is:

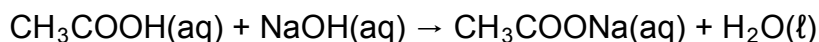

7.1 Define an *acid* in terms of the Arrhenius theory. (2)

7.2 Give a reason why ethanoic acid is classified as a weak acid. (1)

7.3 Explain the meaning of *standard solution*. (1)

7.4 Write down the names of TWO items of apparatus needed to measure accurate volumes of the acid and the base in this titration. (2)

7.5 It is found that 40 ml of a 0,5 mol·dm⁻³ sodium hydroxide solution is needed to neutralise 20 ml of the vinegar.

Calculate the:

7.5.1 pH of the sodium hydroxide solution (4)

7.5.2 Percentage of ethanoic acid by mass present in the vinegar
(Assume that 1 ml of vinegar has a mass of 1 g.) (7)

7.6 The sodium ethanoate (CH₃COONa) formed during the above neutralisation reaction undergoes hydrolysis to form an alkaline solution. Write down an equation for this hydrolysis reaction. (3)
[20]

QUESTION 8 (Start on a new page.)

The voltaic cell represented below functions at standard conditions.

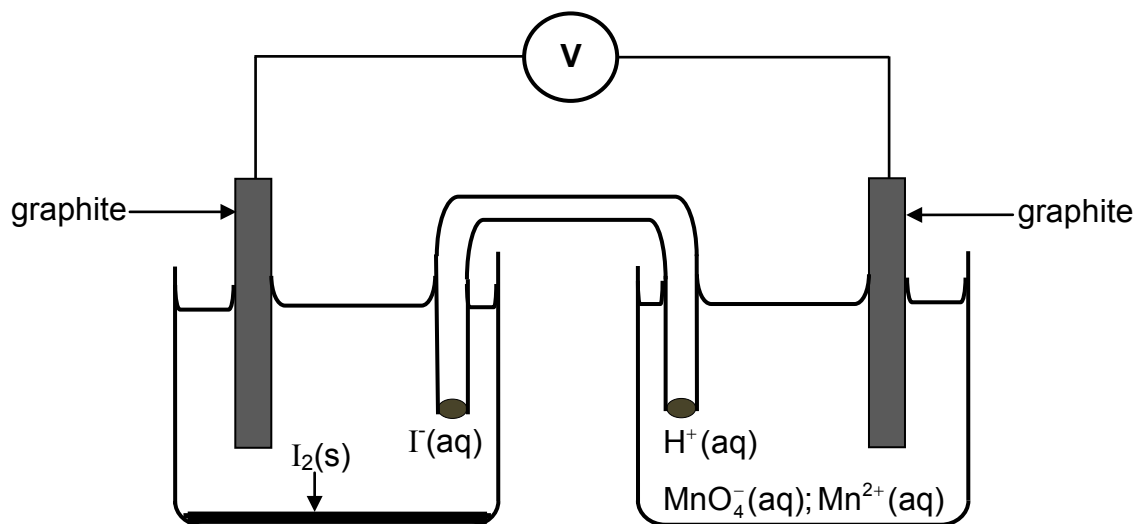

- 8.1 Write down the concentration of $H^+ (aq)$ in the one half-cell. (1)
- 8.2 Solids present in half-cells are usually used as electrodes. Give a reason why $I_2 (s)$ is not suitable to be used as an electrode. (1)
- 8.3 Write down TWO properties of graphite, other than being a solid, that makes it suitable for use as electrodes in the above voltaic cell. (2)
- 8.4 For the above voltaic cell, write down the:
- 8.4.1 NAME of the oxidising agent (1)
- 8.4.2 Net cell reaction (3)
- 8.4.3 Cell notation (3)
- 8.5 Calculate the cell potential of the above cell. (4)
- 8.6 How will the reading on the voltmeter be affected if the concentration of $MnO_4^- (aq)$ decreases? Only write down INCREASES, DECREASES or NO EFFECT. (1)

[16]

QUESTION 9 (Start on a new page.)

A technician is plating a bracelet with chromium in an electrolytic cell containing $\text{Cr}_2(\text{SO}_4)_3(\text{aq})$. A simplified diagram of the electrolytic cell is shown below.

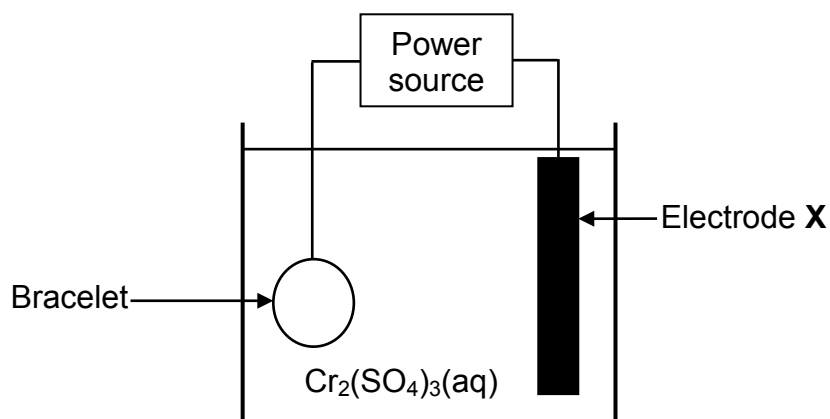

- 9.1 Define the term *electrolyte*. (2)
- 9.2 Which electrode, the BRACELET or X, is the cathode? (1)
- 9.3 Write down the:
- 9.3.1 Metal of which electrode X is made (1)
- 9.3.2 Reduction half-reaction (2)
- 9.4 During the process, the bracelet is plated with 0,86 g of chromium. Calculate the number of electrons transferred during the process. (6)
- [12]**

QUESTION 10 (Start on a new page.)

Sulphuric acid is used, amongst others, in the manufacturing of fertilisers. The flow diagram below shows how fertiliser **D** can be prepared using sulphuric acid as one of the reagents.

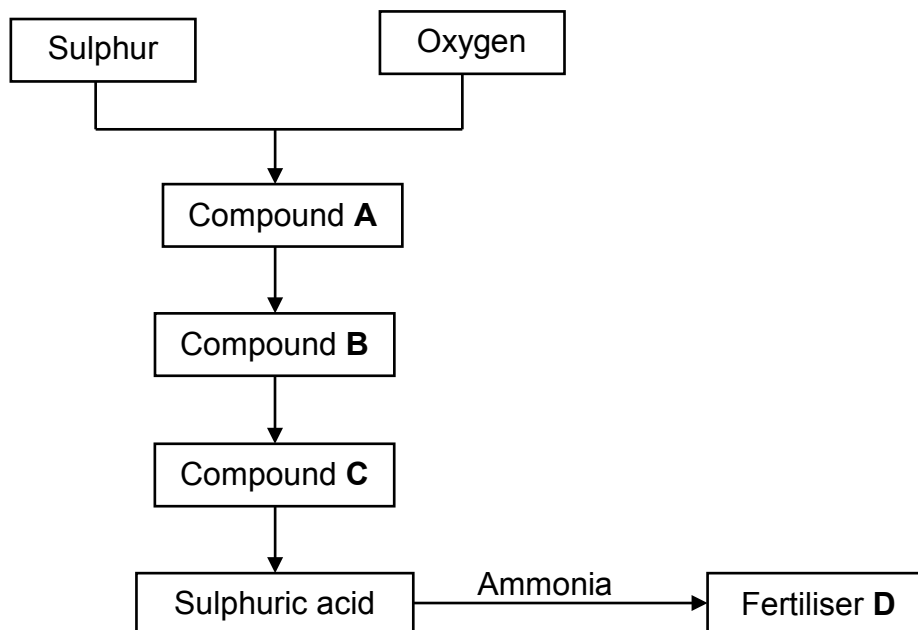

- 10.1 Write down the NAME of the industrial process for the preparation of sulphuric acid. (1)
- 10.2 Compound **A** is formed when sulphur burns in oxygen. Write down the NAME or FORMULA of compound **A**. (1)
- 10.3 Compound **B** is formed when compound **A** reacts with oxygen in the presence of a catalyst. Write down the:
- 10.3.1 NAME or FORMULA of the catalyst (1)
- 10.3.2 Balanced equation for the reaction which takes place (3)
- 10.4 Compound **B** is dissolved in concentrated sulphuric acid to form compound **C**.
Write down the:
- 10.3.1 NAME or FORMULA of compound **C** (1)
- 10.3.2 Reason why compound **B** is not dissolved in water to form sulphuric acid (1)
- 10.5 Write down the NAME or FORMULA of fertiliser **D**. (1)
- 10.6 Inorganic fertilisers are soluble in water. This can result in eutrophication if they are washed off into rivers during heavy rain. Write down ONE negative impact of eutrophication on the economy of a country. (2)

[11]**TOTAL: 150**

**DATA FOR PHYSICAL SCIENCES GRADE 12
PAPER 2 (CHEMISTRY)**

**GEGEWENS VIR FISIESTE WETENSKAPPE GRAAD 12
VRAESTEL 2 (CHEMIE)**

TABLE 1: PHYSICAL CONSTANTS/TABEL 1: FISIESTE KONSTANTES

NAME/NAAM	SYMBOL/SIMBOOL	VALUE/WAARDE
Standard pressure <i>Standaarddruk</i>	p^θ	$1,013 \times 10^5 \text{ Pa}$
Molar gas volume at STP <i>Molêre gasvolume by STD</i>	V_m	$22,4 \text{ dm}^3 \cdot \text{mol}^{-1}$
Standard temperature <i>Standaardtemperatuur</i>	T^θ	273 K
Charge on electron <i>Lading op elektron</i>	e	$-1,6 \times 10^{-19} \text{ C}$
Avogadro's constant <i>Avogadro-konstante</i>	N_A	$6,02 \times 10^{23} \text{ mol}^{-1}$

TABLE 2: FORMULAE/TABEL 2: FORMULES

$n = \frac{m}{M}$	$n = \frac{N}{N_A}$
$c = \frac{n}{V}$ or/of $c = \frac{m}{MV}$	$n = \frac{V}{V_m}$
$\frac{c_a V_a}{c_b V_b} = \frac{n_a}{n_b}$	$\text{pH} = -\log[\text{H}_3\text{O}^+]$
$K_w = [\text{H}_3\text{O}^+][\text{OH}^-] = 1 \times 10^{-14}$ at/by 298 K	
$E_{\text{cell}}^\theta = E_{\text{cathode}}^\theta - E_{\text{anode}}^\theta$ / $E_{\text{sel}}^\theta = E_{\text{katode}}^\theta - E_{\text{anode}}^\theta$	
or/of $E_{\text{cell}}^\theta = E_{\text{reduction}}^\theta - E_{\text{oxidation}}^\theta$ / $E_{\text{sel}}^\theta = E_{\text{reduksie}}^\theta - E_{\text{oksidasie}}^\theta$	
or/of $E_{\text{cell}}^\theta = E_{\text{oxidising agent}}^\theta - E_{\text{reducing agent}}^\theta$ / $E_{\text{sel}}^\theta = E_{\text{oksideermiddel}}^\theta - E_{\text{reduseermiddel}}^\theta$	

TABLE 4A: STANDARD REDUCTION POTENTIALS
TABEL 4A: STANDAARD-REDUKSIEPOTENSIALE

Half-reactions/Halfreaksies	E^{\ominus} (V)
$F_2(g) + 2e^- \rightleftharpoons 2F^-$	+ 2,87
$Co^{3+} + e^- \rightleftharpoons Co^{2+}$	+ 1,81
$H_2O_2 + 2H^+ + 2e^- \rightleftharpoons 2H_2O$	+1,77
$MnO_4^- + 8H^+ + 5e^- \rightleftharpoons Mn^{2+} + 4H_2O$	+ 1,51
$Cl_2(g) + 2e^- \rightleftharpoons 2Cl^-$	+ 1,36
$Cr_2O_7^{2-} + 14H^+ + 6e^- \rightleftharpoons 2Cr^{3+} + 7H_2O$	+ 1,33
$O_2(g) + 4H^+ + 4e^- \rightleftharpoons 2H_2O$	+ 1,23
$MnO_2 + 4H^+ + 2e^- \rightleftharpoons Mn^{2+} + 2H_2O$	+ 1,23
$Pt^{2+} + 2e^- \rightleftharpoons Pt$	+ 1,20
$Br_2(l) + 2e^- \rightleftharpoons 2Br^-$	+ 1,07
$NO_3^- + 4H^+ + 3e^- \rightleftharpoons NO(g) + 2H_2O$	+ 0,96
$Hg^{2+} + 2e^- \rightleftharpoons Hg(l)$	+ 0,85
$Ag^+ + e^- \rightleftharpoons Ag$	+ 0,80
$NO_3^- + 2H^+ + e^- \rightleftharpoons NO_2(g) + H_2O$	+ 0,80
$Fe^{3+} + e^- \rightleftharpoons Fe^{2+}$	+ 0,77
$O_2(g) + 2H^+ + 2e^- \rightleftharpoons H_2O_2$	+ 0,68
$I_2 + 2e^- \rightleftharpoons 2I^-$	+ 0,54
$Cu^+ + e^- \rightleftharpoons Cu$	+ 0,52
$SO_2 + 4H^+ + 4e^- \rightleftharpoons S + 2H_2O$	+ 0,45
$2H_2O + O_2 + 4e^- \rightleftharpoons 4OH^-$	+ 0,40
$Cu^{2+} + 2e^- \rightleftharpoons Cu$	+ 0,34
$SO_4^{2-} + 4H^+ + 2e^- \rightleftharpoons SO_2(g) + 2H_2O$	+ 0,17
$Cu^{2+} + e^- \rightleftharpoons Cu^+$	+ 0,16
$Sn^{4+} + 2e^- \rightleftharpoons Sn^{2+}$	+ 0,15
$S + 2H^+ + 2e^- \rightleftharpoons H_2S(g)$	+ 0,14
$2H^+ + 2e^- \rightleftharpoons H_2(g)$	0,00
$Fe^{3+} + 3e^- \rightleftharpoons Fe$	- 0,06
$Pb^{2+} + 2e^- \rightleftharpoons Pb$	- 0,13
$Sn^{2+} + 2e^- \rightleftharpoons Sn$	- 0,14
$Ni^{2+} + 2e^- \rightleftharpoons Ni$	- 0,27
$Co^{2+} + 2e^- \rightleftharpoons Co$	- 0,28
$Cd^{2+} + 2e^- \rightleftharpoons Cd$	- 0,40
$Cr^{3+} + e^- \rightleftharpoons Cr^{2+}$	- 0,41
$Fe^{2+} + 2e^- \rightleftharpoons Fe$	- 0,44
$Cr^{3+} + 3e^- \rightleftharpoons Cr$	- 0,74
$Zn^{2+} + 2e^- \rightleftharpoons Zn$	- 0,76
$2H_2O + 2e^- \rightleftharpoons H_2(g) + 2OH^-$	- 0,83
$Cr^{2+} + 2e^- \rightleftharpoons Cr$	- 0,91
$Mn^{2+} + 2e^- \rightleftharpoons Mn$	- 1,18
$Al^{3+} + 3e^- \rightleftharpoons Al$	- 1,66
$Mg^{2+} + 2e^- \rightleftharpoons Mg$	- 2,36
$Na^+ + e^- \rightleftharpoons Na$	- 2,71
$Ca^{2+} + 2e^- \rightleftharpoons Ca$	- 2,87
$Sr^{2+} + 2e^- \rightleftharpoons Sr$	- 2,89
$Ba^{2+} + 2e^- \rightleftharpoons Ba$	- 2,90
$Cs^+ + e^- \rightleftharpoons Cs$	- 2,92
$K^+ + e^- \rightleftharpoons K$	- 2,93
$Li^+ + e^- \rightleftharpoons Li$	- 3,05

Increasing oxidising ability/Toenemende oksiderende vermoë

Increasing reducing ability/Toenemende reduserende vermoë

TABLE 4B: STANDARD REDUCTION POTENTIALS
TABEL 4B: STANDAARD-REDUKSIEPOTENSIALE

Increasing oxidising ability/Toenemende oksiderende vermoë

Half-reactions/Halfreaksies	E^{\ominus} (V)
$\text{Li}^+ + \text{e}^- \rightleftharpoons \text{Li}$	-3,05
$\text{K}^+ + \text{e}^- \rightleftharpoons \text{K}$	-2,93
$\text{Cs}^+ + \text{e}^- \rightleftharpoons \text{Cs}$	-2,92
$\text{Ba}^{2+} + 2\text{e}^- \rightleftharpoons \text{Ba}$	-2,90
$\text{Sr}^{2+} + 2\text{e}^- \rightleftharpoons \text{Sr}$	-2,89
$\text{Ca}^{2+} + 2\text{e}^- \rightleftharpoons \text{Ca}$	-2,87
$\text{Na}^+ + \text{e}^- \rightleftharpoons \text{Na}$	-2,71
$\text{Mg}^{2+} + 2\text{e}^- \rightleftharpoons \text{Mg}$	-2,36
$\text{Al}^{3+} + 3\text{e}^- \rightleftharpoons \text{Al}$	-1,66
$\text{Mn}^{2+} + 2\text{e}^- \rightleftharpoons \text{Mn}$	-1,18
$\text{Cr}^{2+} + 2\text{e}^- \rightleftharpoons \text{Cr}$	-0,91
$2\text{H}_2\text{O} + 2\text{e}^- \rightleftharpoons \text{H}_2(\text{g}) + 2\text{OH}^-$	-0,83
$\text{Zn}^{2+} + 2\text{e}^- \rightleftharpoons \text{Zn}$	-0,76
$\text{Cr}^{3+} + 3\text{e}^- \rightleftharpoons \text{Cr}$	-0,74
$\text{Fe}^{2+} + 2\text{e}^- \rightleftharpoons \text{Fe}$	-0,44
$\text{Cr}^{3+} + \text{e}^- \rightleftharpoons \text{Cr}^{2+}$	-0,41
$\text{Cd}^{2+} + 2\text{e}^- \rightleftharpoons \text{Cd}$	-0,40
$\text{Co}^{2+} + 2\text{e}^- \rightleftharpoons \text{Co}$	-0,28
$\text{Ni}^{2+} + 2\text{e}^- \rightleftharpoons \text{Ni}$	-0,27
$\text{Sn}^{2+} + 2\text{e}^- \rightleftharpoons \text{Sn}$	-0,14
$\text{Pb}^{2+} + 2\text{e}^- \rightleftharpoons \text{Pb}$	-0,13
$\text{Fe}^{3+} + 3\text{e}^- \rightleftharpoons \text{Fe}$	-0,06
$2\text{H}^+ + 2\text{e}^- \rightleftharpoons \text{H}_2(\text{g})$	0,00
$\text{S} + 2\text{H}^+ + 2\text{e}^- \rightleftharpoons \text{H}_2\text{S}(\text{g})$	+0,14
$\text{Sn}^{4+} + 2\text{e}^- \rightleftharpoons \text{Sn}^{2+}$	+0,15
$\text{Cu}^{2+} + \text{e}^- \rightleftharpoons \text{Cu}^+$	+0,16
$\text{SO}_4^{2-} + 4\text{H}^+ + 2\text{e}^- \rightleftharpoons \text{SO}_2(\text{g}) + 2\text{H}_2\text{O}$	+0,17
$\text{Cu}^{2+} + 2\text{e}^- \rightleftharpoons \text{Cu}$	+0,34
$2\text{H}_2\text{O} + \text{O}_2 + 4\text{e}^- \rightleftharpoons 4\text{OH}^-$	+0,40
$\text{SO}_2 + 4\text{H}^+ + 4\text{e}^- \rightleftharpoons \text{S} + 2\text{H}_2\text{O}$	+0,45
$\text{Cu}^+ + \text{e}^- \rightleftharpoons \text{Cu}$	+0,52
$\text{I}_2 + 2\text{e}^- \rightleftharpoons 2\text{I}^-$	+0,54
$\text{O}_2(\text{g}) + 2\text{H}^+ + 2\text{e}^- \rightleftharpoons \text{H}_2\text{O}_2$	+0,68
$\text{Fe}^{3+} + \text{e}^- \rightleftharpoons \text{Fe}^{2+}$	+0,77
$\text{NO}_3^- + 2\text{H}^+ + \text{e}^- \rightleftharpoons \text{NO}_2(\text{g}) + \text{H}_2\text{O}$	+0,80
$\text{Ag}^+ + \text{e}^- \rightleftharpoons \text{Ag}$	+0,80
$\text{Hg}^{2+} + 2\text{e}^- \rightleftharpoons \text{Hg}(\ell)$	+0,85
$\text{NO}_3^- + 4\text{H}^+ + 3\text{e}^- \rightleftharpoons \text{NO}(\text{g}) + 2\text{H}_2\text{O}$	+0,96
$\text{Br}_2(\ell) + 2\text{e}^- \rightleftharpoons 2\text{Br}^-$	+1,07
$\text{Pt}^{2+} + 2\text{e}^- \rightleftharpoons \text{Pt}$	+1,20
$\text{MnO}_2 + 4\text{H}^+ + 2\text{e}^- \rightleftharpoons \text{Mn}^{2+} + 2\text{H}_2\text{O}$	+1,23
$\text{O}_2(\text{g}) + 4\text{H}^+ + 4\text{e}^- \rightleftharpoons 2\text{H}_2\text{O}$	+1,23
$\text{Cr}_2\text{O}_7^{2-} + 14\text{H}^+ + 6\text{e}^- \rightleftharpoons 2\text{Cr}^{3+} + 7\text{H}_2\text{O}$	+1,33
$\text{Cl}_2(\text{g}) + 2\text{e}^- \rightleftharpoons 2\text{Cl}^-$	+1,36
$\text{MnO}_4^- + 8\text{H}^+ + 5\text{e}^- \rightleftharpoons \text{Mn}^{2+} + 4\text{H}_2\text{O}$	+1,51
$\text{H}_2\text{O}_2 + 2\text{H}^+ + 2\text{e}^- \rightleftharpoons 2\text{H}_2\text{O}$	+1,77
$\text{Co}^{3+} + \text{e}^- \rightleftharpoons \text{Co}^{2+}$	+1,81
$\text{F}_2(\text{g}) + 2\text{e}^- \rightleftharpoons 2\text{F}^-$	+2,87

Increasing reducing ability/Toenemende reduserende vermoë