



# education

---

Department:  
Education  
**REPUBLIC OF SOUTH AFRICA**

**NATIONAL  
SENIOR CERTIFICATE**

**GRADE 12**

**PHYSICAL SCIENCES: CHEMISTRY (P2)**

**NOVEMBER 2008**

**MARKS: 150**

**TIME: 3 hours**

**This question paper consists of 14 pages, a 4-page data annexure and an answer sheet.**

**INSTRUCTIONS AND INFORMATION**

1. Write your name and/or examination number (and centre number if applicable) in the appropriate spaces on the ANSWER BOOK and ANSWER SHEET.
2. Answer ALL the questions.
3. Answer SECTION A on the attached ANSWER SHEET.
4. Answer SECTION B in the ANSWER BOOK.
5. Number the answers correctly according to the numbering system used in this question paper.
6. Data sheets and a periodic table are attached for your use.
7. Wherever motivations, discussions, et cetera are required, be brief.
8. Non-programmable calculators may be used.
9. Appropriate mathematical instruments may be used.

**SECTION A**

Answer this section on the attached ANSWER SHEET.

**QUESTION 1: ONE-WORD ITEMS**

Give ONE word/term for each of the following descriptions. Write only the word/term next to the question number (1.1 – 1.5) on the attached ANSWER SHEET.

- 1.1 A reaction in which the temperature of the mixture decreases (1)
- 1.2 The type of equilibrium in which the macroscopic properties (those visible to the naked eye) of the reaction mixture remain unchanged (1)
- 1.3 A loss of electrons during a redox reaction (1)
- 1.4 The electrolytic cell used for the industrial preparation of chlorine gas (1)
- 1.5 Atoms, groups of atoms or bonds that can be used to identify a homologous series (1)
- [5]**

**QUESTION 2: MATCHING ITEMS**

Choose an item from COLUMN B that matches a description in COLUMN A. Write only the letter (A – J) next to the question number (2.1 – 2.5) on the attached ANSWER SHEET.

COLUMN A		COLUMN B	
2.1	An aromatic hydrocarbon	A	anode
2.2	A unit in which reaction rate is measured	B	volt
2.3	Equilibria where all the reagents are in the same phase	C	mol·dm <sup>-3</sup>
2.4	The positive electrode of an electrolytic cell	D	benzene
2.5	A unit in which battery capacity is measured	E	heterogeneous
		F	mol·s <sup>-1</sup>
		G	cathode
		H	cyclohexene
		I	ampere-hour
		J	homogeneous

**[5]**

**QUESTION 3: TRUE OR FALSE**

Indicate whether the following statements are TRUE or FALSE. Write only 'true' or 'false' next to the question number (3.1 – 3.5) on the attached ANSWER SHEET. Correct the statement if it is FALSE.

3.1 Esters and carboxylic acids can both be represented by the general formula  $C_nH_{2n}O_2$ . (2)

3.2 When the solution in equilibrium represented below is heated, it turns green.

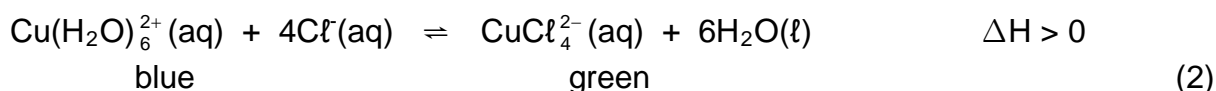

3.3 For the hypothetical reaction:

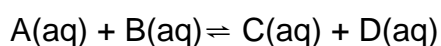

If at equilibrium  $K_C = 10^{-4}$ , then  $[A][B] < [C][D]$ . (2)

3.4 Zinc(II) sulphate can oxidise aluminium. (2)

3.5 During the catalytic oxidation of ammonia the platinum ensures a high concentration of products. (2)  
[10]

**QUESTION 4: MULTIPLE-CHOICE QUESTIONS**

Four options are provided as possible answers to the following questions. Each question has only ONE correct answer. Choose the answer and make a cross (X) in the block (A – D) next to the question number (4.1 – 4.5) on the attached ANSWER SHEET.

4.1 The condensed structural formula of an organic compound is given below.

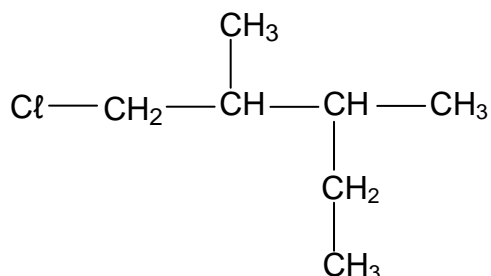

Which ONE of the following is the correct IUPAC name of this compound?

- A 1-chloro-2,3-dimethylbutane
- B 1-chloro-2,3-dimethylpentane
- C 1-chloro-3-ethyl-2-methylbutane
- D 1-chloro-2-ethyl-3-methylpentane (3)

4.2 The boiling points of branched alkanes are lower than those of straight chain alkanes containing the same number of carbon atoms because branched alkane chains have ...

- A larger molecular masses.
- B shorter chain lengths.
- C more electrons.
- D smaller effective molecular surface areas.

(3)

4.3 Which ONE of the following statements about the rate of reaction is INCORRECT?

- A Meat decays quicker in a warm environment than in a fridge.
- B Most industrial processes are cheaper to run when a catalyst is used.
- C Zinc reacts faster with excess dilute hydrochloric acid than with concentrated hydrochloric acid that is not in excess.
- D Potatoes cook faster when sliced than when cooked whole.

(3)

4.4 The diagram below shows a cell used to prepare chlorine gas and sodium hydroxide.

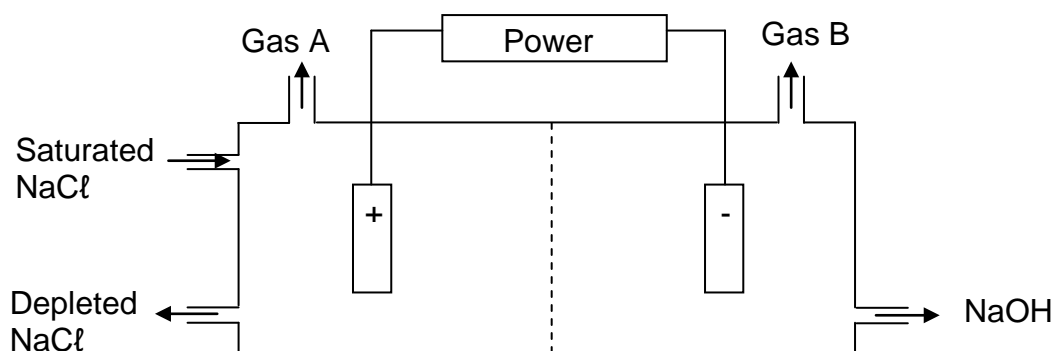

Which ONE of the following is applicable to the cell while it is functioning?

	Reaction at positive electrode	Gas A	Gas B
A	oxidation	hydrogen	chlorine
B	reduction	chlorine	hydrogen
C	oxidation	chlorine	hydrogen
D	oxidation	chlorine	oxygen

(3)

4.5 Nitrogen, phosphorus and potassium are ingredients in fertilisers. They are essential nutrients for plant growth and have the following functions:

- Nitrogen – for rapid growth and green leaves
- Phosphorus – for strong roots, fruit and flower development
- Potassium – protects against cold and dry weather

Your lawn has a well developed root system. You need a fertiliser that will provide nutrients for rapid growth and green leaves, and to protect the lawn during extreme dry conditions. Which ONE of the following fertiliser mixtures will you use on your lawn?

A 7:1:1

B 1:1:5

C 2:5:1

D 8:1:5

(3)  
[15]

**TOTAL SECTION A: 35**

**SECTION B****INSTRUCTIONS**

1. Answer this section in the ANSWER BOOK.
2. The formulae and substitutions must be shown in ALL calculations.
3. Round off your answers to TWO decimal places.

**QUESTION 5**

Ethene is a gaseous hormone associated with the ripening of fruit. It also contributes to the ageing and distortion of plants. In industry, the artificial ripening of fruit takes place when ethene is passed over the fruit in large rooms. After a while the ripening fruit releases its own ethene.

- 5.1 Write down the structural formula of ethene. (2)
- 5.2 Why is it not advisable to place a banana that has been artificially ripened alongside a cabbage and lettuce? (2)

In industry ethene is also used to synthesise a variety of organic compounds.

The flow diagram below illustrates some of the many reactions ethene undergoes.

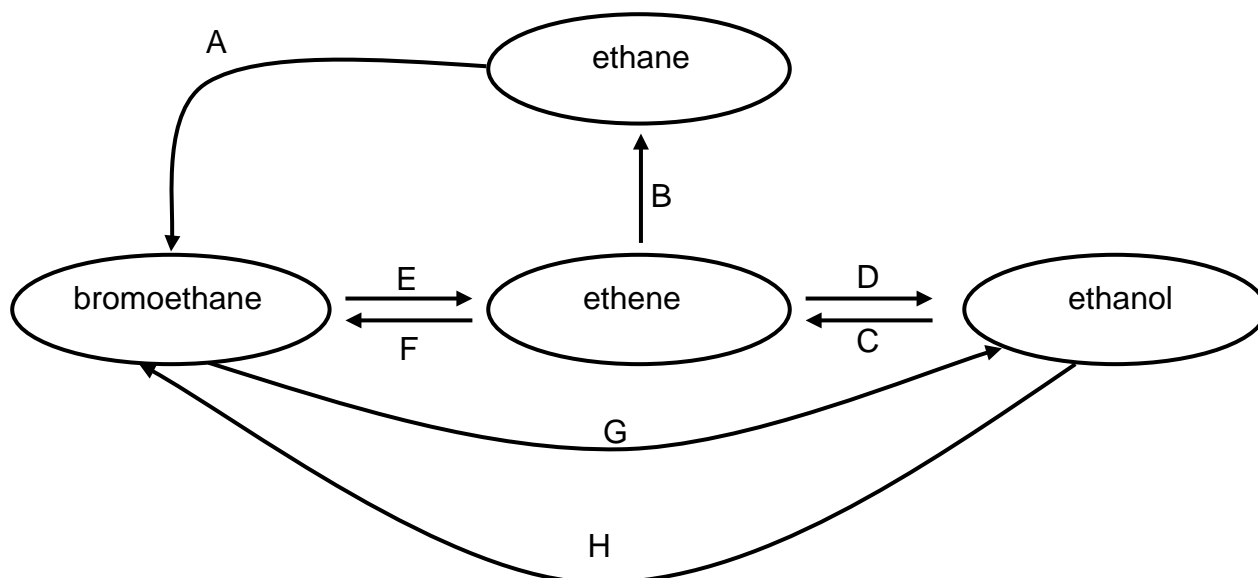

- 5.3 Write down the general formula for the homologous series to which ethene belongs. (1)
- 5.4 Name the type of reaction represented by each of the letters A, B, D and H. Write down the letters A, B, D and H and next to each the type of reaction. (4)
- 5.5 Use structural formulae to write down a balanced equation for reaction B. (3)

- 5.6 Apart from ethene, which other reactant is needed for reaction F? Write down the FORMULA only. (2)
- 5.7 Both reactions E and G occur in the presence of a base. Reaction E is an elimination reaction and reaction G is a substitution reaction.
- 5.7.1 How is the base in reaction E different from the base in reaction G? (2)
- 5.7.2 Name the type of elimination reaction represented by E. (1)
- [17]**

**QUESTION 6**

You have two test tubes containing equal amounts of compounds X and Y respectively. Both have the same molecular formula  $C_5H_{10}$ . You have to distinguish which compound, X or Y, is saturated.

You hypothesise that compound X is saturated.

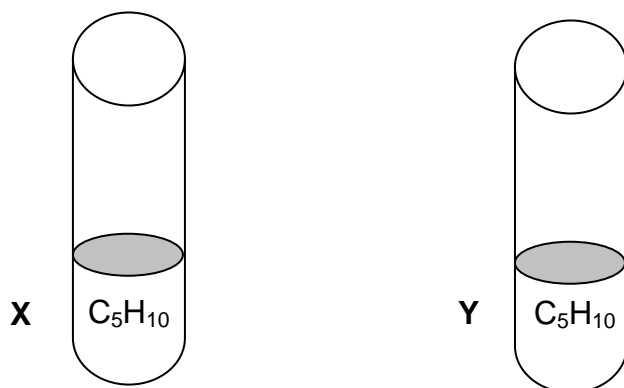

- 6.1 Design an investigation to show that your hypothesis is true. Use the following to write down your design (write only the question number and next to it your answer):
- 6.1.1 Write down your investigative question. (2)
- 6.1.2 Write down a list of apparatus and chemicals you will use. (2)
- 6.1.3 State the safety precautions that you will take. (2)
- 6.1.4 Write down the procedure you will follow. (4)
- 6.2 Describe how you will use your observations to verify your hypothesis. (2)
- 6.3 Write down the IUPAC name of compound Y. (2)
- [14]**



**QUESTION 7**

More than 90 million organic compounds are known to man today. In the table below the letters A to E represent a few of these compounds.

	<b>COMPOUND</b>
A	$\begin{array}{c} \text{CH}_3 \text{ CH}_2 \text{ CH}_2 \text{ COH} \\ \parallel \\ \text{O} \end{array}$
B	trimethylamine
C	$\begin{array}{c} \text{CH}_3 - \text{CH} - \text{CH}_3 \\   \\ \text{OH} \end{array}$
D	6-methyl-1-heptene
E	$\begin{array}{c} \text{O} \quad \text{CH}_3 \\ \parallel \quad   \\ \text{CH}_3 - \text{C} - \text{N} - \text{CH}_3 \end{array}$

- 7.1 Write down the IUPAC name of compound A. (1)
- 7.2 Write down the structural formula of compound D. (2)
- 7.3 To which homologous series does compound E belong? (1)
- 7.4 Write down the IUPAC name of an isomer of compound C. (2)
- 7.5 Compound B is one of the substances responsible for the fishy odour (smell) of fish. Explain why serving lemon slices with fish reduces the odour. (2)

**[8]**

**QUESTION 8**

8.1 The collision theory can be used to explain how different factors affect the rate of a chemical reaction.

8.1.1 Name TWO conditions that determine whether a collision between two molecules, A and B, will lead to a chemical reaction. (2)

8.1.2 In terms of the collision theory, explain why the rate of a chemical reaction increases with increasing temperature. (2)

8.2 The reaction between nitrogen dioxide and carbon monoxide is represented below.

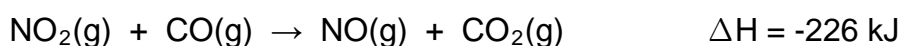

The activation energy for the reaction,  $E_a$ , is 132 kJ.

8.2.1 Sketch a potential energy versus reaction coordinate graph for this reaction. Label the axes and indicate the following on your graph:

$$\begin{aligned} \Delta H &= -226 \text{ kJ} \\ E_a &= 132 \text{ kJ} \end{aligned} \quad (4)$$

8.2.2 Use a broken line on your graph to show the effect a catalyst would have on the potential energy as the reaction proceeds. (1)

**[9]**

**QUESTION 9**

In olden times the fertility of soil was achieved by allowing the land to lie fallow (unused). Alternatively, natural fertilisers such as manure and ground animal bones, which were ground, were used. Scientific research later established that fertilisers contained large quantities of nitrogen (N), phosphorus (P) and potassium (K).

While it was easy to obtain the minerals, the sources of nitrogen were very limited. As the world population grew, so did the demand for nitrogen-rich fertilisers. At the same time the sources of nitrogen were being depleted.

Fritz Haber designed a process which used nitrogen from the air and hydrogen from natural gas to manufacture ammonia. The process was also used to make ammonium nitrate which was used to manufacture explosives during World War I. Today the ammonia produced is used in the plastic industry and in many other products.

9.1 Write down TWO positive and TWO negative impacts of the Haber process on human and social development. (4)

The following equation represents a reversible reaction that has reached equilibrium at 470 °C in a closed container:

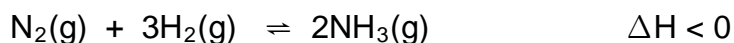

A change was then made to the  $\text{NH}_3$  in the equilibrium mixture at  $t_2$ . A graph showing the effect of this change is drawn below. (The graph is not drawn to scale.)

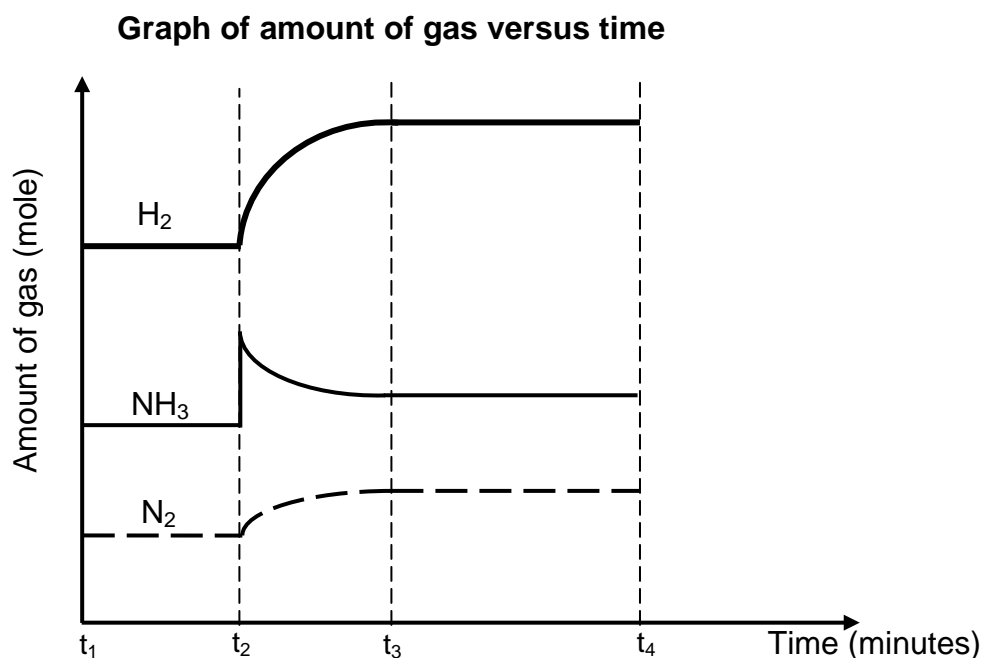

- 9.2 What is the meaning of the horizontal lines between  $t_1$  and  $t_2$ ? (1)
- 9.3 State the change that was made to the  $\text{NH}_3$  in the mixture at time  $t_2$ . (1)
- 9.4 Explain how the change mentioned in QUESTION 9.3, affected the concentration of  $\text{H}_2$  and  $\text{N}_2$  gases as shown in the graph. (3)

1,5 mol of  $\text{N}_2(\text{g})$  and 2 mol  $\text{H}_2(\text{g})$  were injected into a  $0,5 \text{ dm}^3$  closed reaction vessel and allowed to reach equilibrium at 470 °C. When equilibrium was reached it was found that 1 mol of  $\text{NH}_3(\text{g})$  was present.

- 9.5 Calculate the equilibrium constant ( $K_C$ ) at 470 °C. Show ALL your calculations. (8)
- 9.6 The temperature is now increased to 800 °C.
- 9.6.1 How will the value of  $K_C$  be affected if the temperature is increased to 800 °C? Write down only INCREASES or DECREASES or REMAINS THE SAME. (1)
- 9.6.2 Explain your answer to QUESTION 9.6.1. (2)

**[20]**

**QUESTION 10**

- 10.1 Rusting is an unwanted redox reaction. Iron rusts when exposed to oxygen and moisture. The unbalanced ionic equation for one reaction that occurs during rusting is represented below.

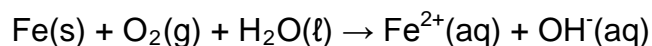

Use the Table of Standard Reduction Potentials (Table 4A or 4B) to answer the following questions for this reaction.

- 10.1.1 Write down the oxidation half-reaction. (2)
- 10.1.2 Write down the NAME of the substance that is reduced. (1)
- 10.1.3 Perform a calculation to verify that this reaction is spontaneous. (5)
- 10.2 Magnesium is used to protect underground iron pipes against rusting. The diagram below shows an iron pipe connected to a magnesium bar.

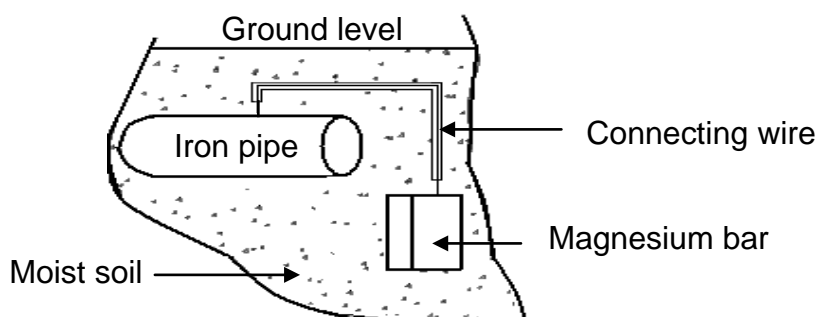

- 10.2.1 Use the Table of Standard Reduction Potentials (Table 4A or 4B) to explain why magnesium can be used to protect an iron pipe against rusting. (2)
- 10.2.2 The iron pipe in contact with the magnesium bar forms an electrochemical cell. What serves as the salt bridge of this cell? (2)
- 10.2.3 Give a reason why the magnesium bar must be replaced after some time. (1)
- 10.2.4 Write down a half-reaction to support your answer to QUESTION 10.2.3. (2)
- 10.2.5 Name TWO other methods that can be used to protect iron pipes against rust. (2)
- 10.2.6 State ONE advantage and ONE disadvantage of using plastic pipes instead of iron pipes. (2)

**[19]**

**QUESTION 11**

Aluminium is one of the most abundant metals on earth, yet it is expensive – largely because of the amount of electricity needed to extract it. Aluminium ore is called bauxite. The bauxite is purified to yield a white powder, aluminium oxide, from which aluminium can be extracted.

The diagram below shows an electrolytic cell used for the extraction of aluminium at temperatures as high as 1 000 °C.

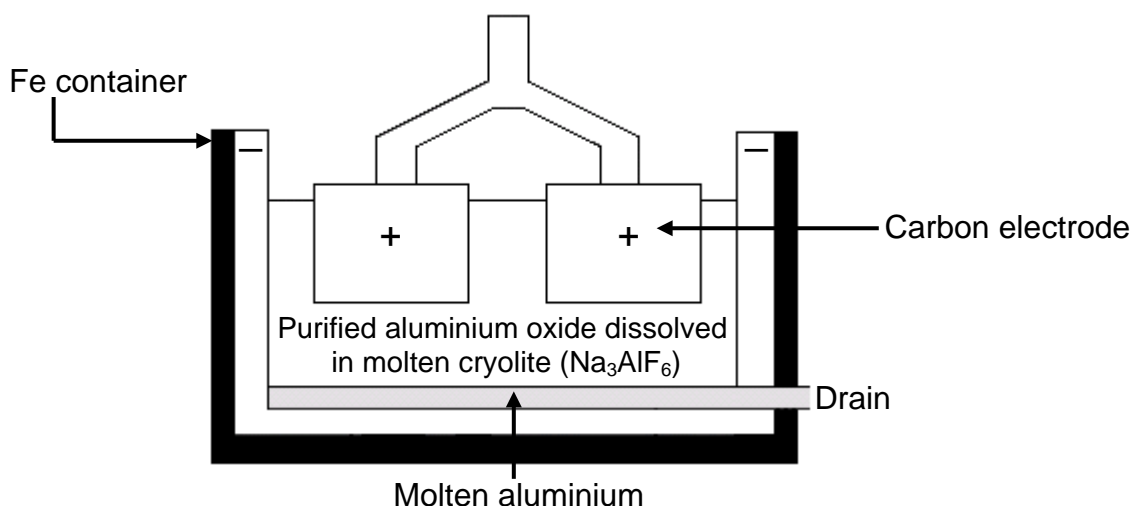

- 11.1 State the energy conversion that takes place in this electrolytic cell. (2)
- 11.2 Is aluminium formed at the positive or negative electrode? Write down POSITIVE or NEGATIVE only. (1)
- 11.3 Use the Table of Standard Reduction Potentials (Table 4A or 4B) to write down the half-reaction for the formation of aluminium. (2)
- 11.4 Explain why carbon dioxide gas is formed at one of the electrodes. (2)
- 11.5 Why should the carbon electrodes be replaced regularly? (2)
- 11.6 Write down TWO negative effects that the extraction of aluminium can have on the environment. (2)

**[11]**

**QUESTION 12****DEAD ZONES EMERGING AS A BIG THREAT TO 21<sup>ST</sup> CENTURY FISH STOCKS**

There are nearly 200 oxygen-starved or 'dead' zones in the world's oceans and seas. These 'dead' zones are linked to eutrophication caused by agricultural fertilisers, vehicle and factory emissions and wastes. Low levels of oxygen in the water make it difficult for important habitats such as sea grass beds, as well as organisms such as fish, oysters and other marine creatures, to survive.

Nitrogen shortages are reducing farmers' chances of meeting food demands in parts of Africa. In many other parts of the world, however, excessive use of fertilisers is contributing to the escalating problem of 'dead' zones.

[Adapted from: *United Nations environmental programme*, News Centre, 2006]

- 12.1 Describe the process of eutrophication in water and how it leads to dead zones. (4)
- 12.2 Natural eutrophication takes place over thousands of years. Humans accelerate this process. Name TWO ways in which they do this. (2)
- 12.3 The flow diagram below represents the conversion of ammonia into nitrates.

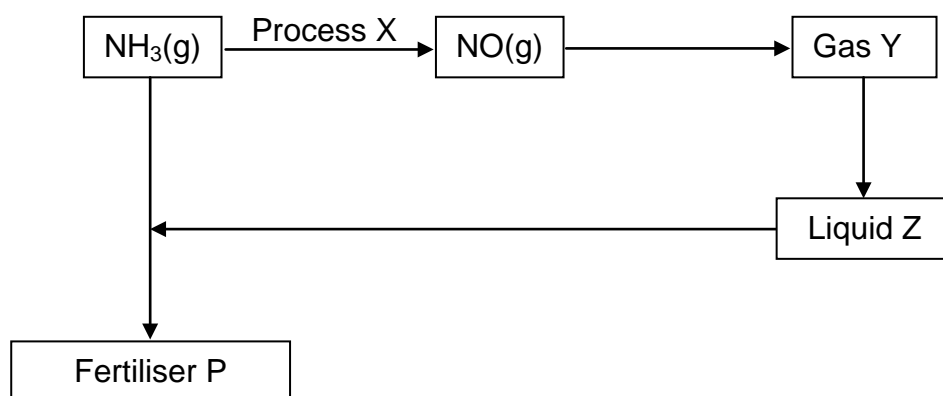

- 12.3.1 What is the name of Process X? (1)
- 12.3.2 Write down a balanced equation for Process X. (3)
- 12.3.3 Write down the FORMULA for Gas Y. (2)
- 12.3.4 Write down a balanced equation for the preparation of fertiliser P. (3)
- 12.4 Name TWO ways according to which eutrophication can be reduced. (2)
- [17]**

**TOTAL SECTION B: 115**

**GRAND TOTAL: 150**

**NATIONAL SENIOR CERTIFICATE  
NASIONALE SENIOR SERTIFIKAAT**

**DATA FOR PHYSICAL SCIENCES GRADE 12  
PAPER 2 (CHEMISTRY)**

**GEGEWENS VIR FISIESE WETENSKAPPE GRAAD 12  
VRAESTEL 2 (CHEMIE)**

**TABLE 1: PHYSICAL CONSTANTS/TABEL 1: FISIESE KONSTANTES**

NAME/NAAM	SYMBOL/SIMBOOL	VALUE/WAARDE
Standard pressure <i>Standaarddruk</i>	$p^\theta$	$1,013 \times 10^5 \text{ Pa}$
Molar gas volume at STP <i>Molêre gasvolume by STD</i>	$V_m$	$22,4 \text{ dm}^3 \cdot \text{mol}^{-1}$
Standard temperature <i>Standaardtemperatuur</i>	$T^\theta$	273 K

**TABLE 2: FORMULAE/TABEL 2: FORMULES**

$n = \frac{m}{M}$	$c = \frac{n}{V}$
$c = \frac{m}{MV}$	$E_{\text{cell}}^\theta = E_{\text{cathode}}^\theta - E_{\text{anode}}^\theta / E_{\text{sel}}^\theta = E_{\text{katode}}^\theta - E_{\text{anode}}^\theta$ $E_{\text{cell}}^\theta = E_{\text{reduction}}^\theta - E_{\text{oxidation}}^\theta / E_{\text{sel}}^\theta = E_{\text{reduksie}}^\theta - E_{\text{oksidasie}}^\theta$ $E_{\text{cell}}^\theta = E_{\text{oxidising agent}}^\theta - E_{\text{reducing agent}}^\theta / E_{\text{sel}}^\theta = E_{\text{oksideermiddel}}^\theta - E_{\text{reduseermiddel}}^\theta$

**TABLE 3: THE PERIODIC TABLE OF ELEMENTS**  
**TABEL 3: DIE PERIODIEKE TABEL VAN ELEMENTE**

1 (I)	2 (II)	3	4	5	6	7	8	9	10	11	12	13 (III)	14 (IV)	15 (V)	16 (VI)	17 (VII)	18 (VIII)
1 H 1																	2 He 4
3 Li 7	4 Be 9											5 B 11	6 C 12	7 N 14	8 O 16	9 F 19	10 Ne 20
11 Na 23	12 Mg 24											13 Al 27	14 Si 28	15 P 31	16 S 32	17 Cl 35,5	18 Ar 40
19 K 39	20 Ca 40	21 Sc 45	22 Ti 48	23 V 51	24 Cr 52	25 Mn 55	26 Fe 56	27 Co 59	28 Ni 59	29 Cu 63,5	30 Zn 65	31 Ga 70	32 Ge 73	33 As 75	34 Se 79	35 Br 80	36 Kr 84
37 Rb 86	38 Sr 88	39 Y 89	40 Zr 91	41 Nb 92	42 Mo 96	43 Tc 98	44 Ru 101	45 Rh 103	46 Pd 106	47 Ag 108	48 Cd 112	49 In 115	50 Sn 119	51 Sb 122	52 Te 128	53 I 127	54 Xe 131
55 Cs 133	56 Ba 137	57 La 139	72 Hf 179	73 Ta 181	74 W 184	75 Re 186	76 Os 190	77 Ir 192	78 Pt 195	79 Au 197	80 Hg 201	81 Tl 204	82 Pb 207	83 Bi 209	84 Po 209	85 At 210	86 Rn 222
87 Fr 223	88 Ra 226	89 Ac															
			58 Ce 140	59 Pr 141	60 Nd 144	61 Pm	62 Sm 150	63 Eu 152	64 Gd 157	65 Tb 159	66 Dy 163	67 Ho 165	68 Er 167	69 Tm 169	70 Yb 173	71 Lu 175	
			90 Th 232	91 Pa 231	92 U 238	93 Np	94 Pu	95 Am	96 Cm	97 Bk	98 Cf	99 Es	100 Fm	101 Md	102 No	103 Lr	

KEY/SLEUTEL

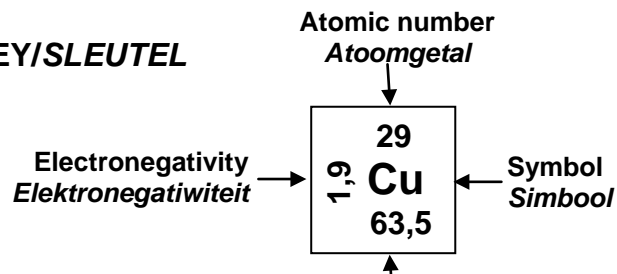



TABLE 4A: STANDARD REDUCTION POTENTIALS  
 TABEL 4A: STANDAARD REDUKSIEPOTENSIALE

Half-reactions/Halfreaksies	$E^{\ominus}$ (V)
$F_2(g) + 2e^- \rightleftharpoons 2F^-$	+ 2,87
$Co^{3+} + e^- \rightleftharpoons Co^{2+}$	+ 1,81
$H_2O_2 + 2H^+ + 2e^- \rightleftharpoons 2H_2O$	+1,77
$MnO_4^- + 8H^+ + 5e^- \rightleftharpoons Mn^{2+} + 4H_2O$	+ 1,51
$Cl_2(g) + 2e^- \rightleftharpoons 2Cl^-$	+ 1,36
$Cr_2O_7^{2-} + 14H^+ + 6e^- \rightleftharpoons 2Cr^{3+} + 7H_2O$	+ 1,33
$O_2(g) + 4H^+ + 4e^- \rightleftharpoons 2H_2O$	+ 1,23
$MnO_2 + 4H^+ + 2e^- \rightleftharpoons Mn^{2+} + 2H_2O$	+ 1,23
$Pt^{2+} + 2e^- \rightleftharpoons Pt$	+ 1,20
$Br_2(l) + 2e^- \rightleftharpoons 2Br^-$	+ 1,07
$NO_3^- + 4H^+ + 3e^- \rightleftharpoons NO(g) + 2H_2O$	+ 0,96
$Hg^{2+} + 2e^- \rightleftharpoons Hg(l)$	+ 0,85
$Ag^+ + e^- \rightleftharpoons Ag$	+ 0,80
$NO_3^- + 2H^+ + e^- \rightleftharpoons NO_2(g) + H_2O$	+ 0,80
$Fe^{3+} + e^- \rightleftharpoons Fe^{2+}$	+ 0,77
$O_2(g) + 2H^+ + 2e^- \rightleftharpoons H_2O_2$	+ 0,68
$I_2 + 2e^- \rightleftharpoons 2I^-$	+ 0,54
$Cu^+ + e^- \rightleftharpoons Cu$	+ 0,52
$SO_2 + 4H^+ + 4e^- \rightleftharpoons S + 2H_2O$	+ 0,45
$2H_2O + O_2 + 4e^- \rightleftharpoons 4OH^-$	+ 0,40
$Cu^{2+} + 2e^- \rightleftharpoons Cu$	+ 0,34
$SO_4^{2-} + 4H^+ + 2e^- \rightleftharpoons SO_2(g) + 2H_2O$	+ 0,17
$Cu^{2+} + e^- \rightleftharpoons Cu^+$	+ 0,16
$Sn^{4+} + 2e^- \rightleftharpoons Sn^{2+}$	+ 0,15
$S + 2H^+ + 2e^- \rightleftharpoons H_2S(g)$	+ 0,14
<b><math>2H^+ + 2e^- \rightleftharpoons H_2(g)</math></b>	<b>0,00</b>
$Fe^{3+} + 3e^- \rightleftharpoons Fe$	- 0,06
$Pb^{2+} + 2e^- \rightleftharpoons Pb$	- 0,13
$Sn^{2+} + 2e^- \rightleftharpoons Sn$	- 0,14
$Ni^{2+} + 2e^- \rightleftharpoons Ni$	- 0,27
$Co^{2+} + 2e^- \rightleftharpoons Co$	- 0,28
$Cd^{2+} + 2e^- \rightleftharpoons Cd$	- 0,40
$Cr^{3+} + e^- \rightleftharpoons Cr^{2+}$	- 0,41
$Fe^{2+} + 2e^- \rightleftharpoons Fe$	- 0,44
$Cr^{3+} + 3e^- \rightleftharpoons Cr$	- 0,74
$Zn^{2+} + 2e^- \rightleftharpoons Zn$	- 0,76
$2H_2O + 2e^- \rightleftharpoons H_2(g) + 2OH^-$	- 0,83
$Cr^{2+} + 2e^- \rightleftharpoons Cr$	- 0,91
$Mn^{2+} + 2e^- \rightleftharpoons Mn$	- 1,18
$Al^{3+} + 3e^- \rightleftharpoons Al$	- 1,66
$Mg^{2+} + 2e^- \rightleftharpoons Mg$	- 2,36
$Na^+ + e^- \rightleftharpoons Na$	- 2,71
$Ca^{2+} + 2e^- \rightleftharpoons Ca$	- 2,87
$Sr^{2+} + 2e^- \rightleftharpoons Sr$	- 2,89
$Ba^{2+} + 2e^- \rightleftharpoons Ba$	- 2,90
$Cs^+ + e^- \rightleftharpoons Cs$	- 2,92
$K^+ + e^- \rightleftharpoons K$	- 2,93
$Li^+ + e^- \rightleftharpoons Li$	- 3,05

Increasing oxidising ability/Toenemende oksiderende vermoë

Increasing reducing ability/Toenemende reduserende vermoë

**TABLE 4B: STANDARD REDUCTION POTENTIALS**  
**TABEL 4B: STANDAARD REDUKSIEPOTENSIALE**

Half-reactions/Halfreaksies	$E^{\ominus}$ (V)
$\text{Li}^+ + \text{e}^- \rightleftharpoons \text{Li}$	- 3,05
$\text{K}^+ + \text{e}^- \rightleftharpoons \text{K}$	- 2,93
$\text{Cs}^+ + \text{e}^- \rightleftharpoons \text{Cs}$	- 2,92
$\text{Ba}^{2+} + 2\text{e}^- \rightleftharpoons \text{Ba}$	- 2,90
$\text{Sr}^{2+} + 2\text{e}^- \rightleftharpoons \text{Sr}$	- 2,89
$\text{Ca}^{2+} + 2\text{e}^- \rightleftharpoons \text{Ca}$	- 2,87
$\text{Na}^+ + \text{e}^- \rightleftharpoons \text{Na}$	- 2,71
$\text{Mg}^{2+} + 2\text{e}^- \rightleftharpoons \text{Mg}$	- 2,36
$\text{Al}^{3+} + 3\text{e}^- \rightleftharpoons \text{Al}$	- 1,66
$\text{Mn}^{2+} + 2\text{e}^- \rightleftharpoons \text{Mn}$	- 1,18
$\text{Cr}^{2+} + 2\text{e}^- \rightleftharpoons \text{Cr}$	- 0,91
$2\text{H}_2\text{O} + 2\text{e}^- \rightleftharpoons \text{H}_2(\text{g}) + 2\text{OH}^-$	- 0,83
$\text{Zn}^{2+} + 2\text{e}^- \rightleftharpoons \text{Zn}$	- 0,76
$\text{Cr}^{3+} + 3\text{e}^- \rightleftharpoons \text{Cr}$	- 0,74
$\text{Fe}^{2+} + 2\text{e}^- \rightleftharpoons \text{Fe}$	- 0,44
$\text{Cr}^{3+} + \text{e}^- \rightleftharpoons \text{Cr}^{2+}$	- 0,41
$\text{Cd}^{2+} + 2\text{e}^- \rightleftharpoons \text{Cd}$	- 0,40
$\text{Co}^{2+} + 2\text{e}^- \rightleftharpoons \text{Co}$	- 0,28
$\text{Ni}^{2+} + 2\text{e}^- \rightleftharpoons \text{Ni}$	- 0,27
$\text{Sn}^{2+} + 2\text{e}^- \rightleftharpoons \text{Sn}$	- 0,14
$\text{Pb}^{2+} + 2\text{e}^- \rightleftharpoons \text{Pb}$	- 0,13
$\text{Fe}^{3+} + 3\text{e}^- \rightleftharpoons \text{Fe}$	- 0,06
<b><math>2\text{H}^+ + 2\text{e}^- \rightleftharpoons \text{H}_2(\text{g})</math></b>	<b>0,00</b>
$\text{S} + 2\text{H}^+ + 2\text{e}^- \rightleftharpoons \text{H}_2\text{S}(\text{g})$	+ 0,14
$\text{Sn}^{4+} + 2\text{e}^- \rightleftharpoons \text{Sn}^{2+}$	+ 0,15
$\text{Cu}^{2+} + \text{e}^- \rightleftharpoons \text{Cu}^+$	+ 0,16
$\text{SO}_4^{2-} + 4\text{H}^+ + 2\text{e}^- \rightleftharpoons \text{SO}_2(\text{g}) + 2\text{H}_2\text{O}$	+ 0,17
$\text{Cu}^{2+} + 2\text{e}^- \rightleftharpoons \text{Cu}$	+ 0,34
$2\text{H}_2\text{O} + \text{O}_2 + 4\text{e}^- \rightleftharpoons 4\text{OH}^-$	+ 0,40
$\text{SO}_2 + 4\text{H}^+ + 4\text{e}^- \rightleftharpoons \text{S} + 2\text{H}_2\text{O}$	+ 0,45
$\text{Cu}^+ + \text{e}^- \rightleftharpoons \text{Cu}$	+ 0,52
$\text{I}_2 + 2\text{e}^- \rightleftharpoons 2\text{I}^-$	+ 0,54
$\text{O}_2(\text{g}) + 2\text{H}^+ + 2\text{e}^- \rightleftharpoons \text{H}_2\text{O}_2$	+ 0,68
$\text{Fe}^{3+} + \text{e}^- \rightleftharpoons \text{Fe}^{2+}$	+ 0,77
$\text{NO}_3^- + 2\text{H}^+ + \text{e}^- \rightleftharpoons \text{NO}_2(\text{g}) + \text{H}_2\text{O}$	+ 0,80
$\text{Ag}^+ + \text{e}^- \rightleftharpoons \text{Ag}$	+ 0,80
$\text{Hg}^{2+} + 2\text{e}^- \rightleftharpoons \text{Hg}(\ell)$	+ 0,85
$\text{NO}_3^- + 4\text{H}^+ + 3\text{e}^- \rightleftharpoons \text{NO}(\text{g}) + 2\text{H}_2\text{O}$	+ 0,96
$\text{Br}_2(\ell) + 2\text{e}^- \rightleftharpoons 2\text{Br}^-$	+ 1,07
$\text{Pt}^{2+} + 2\text{e}^- \rightleftharpoons \text{Pt}$	+ 1,20
$\text{MnO}_2 + 4\text{H}^+ + 2\text{e}^- \rightleftharpoons \text{Mn}^{2+} + 2\text{H}_2\text{O}$	+ 1,23
$\text{O}_2(\text{g}) + 4\text{H}^+ + 4\text{e}^- \rightleftharpoons 2\text{H}_2\text{O}$	+ 1,23
$\text{Cr}_2\text{O}_7^{2-} + 14\text{H}^+ + 6\text{e}^- \rightleftharpoons 2\text{Cr}^{3+} + 7\text{H}_2\text{O}$	+ 1,33
$\text{Cl}_2(\text{g}) + 2\text{e}^- \rightleftharpoons 2\text{Cl}^-$	+ 1,36
$\text{MnO}_4^- + 8\text{H}^+ + 5\text{e}^- \rightleftharpoons \text{Mn}^{2+} + 4\text{H}_2\text{O}$	+ 1,51
$\text{H}_2\text{O}_2 + 2\text{H}^+ + 2\text{e}^- \rightleftharpoons 2\text{H}_2\text{O}$	+ 1,77
$\text{Co}^{3+} + \text{e}^- \rightleftharpoons \text{Co}^{2+}$	+ 1,81
$\text{F}_2(\text{g}) + 2\text{e}^- \rightleftharpoons 2\text{F}^-$	+ 2,87

Increasing oxidising ability/Toenemende oksiderende vermoë

Increasing reducing ability/Toenemende reduserende vermoë

<b>NAME/EXAMINATION NUMBER</b>																			
--------------------------------	--	--	--	--	--	--	--	--	--	--	--	--	--	--	--	--	--	--	--

**ANSWER SHEET****QUESTION 1**

1.1 \_\_\_\_\_ (1)

1.2 \_\_\_\_\_ (1)

1.3 \_\_\_\_\_ (1)

1.4 \_\_\_\_\_ (1)

1.5 \_\_\_\_\_ (1)

**[5]****QUESTION 2**

2.1 \_\_\_\_\_ (1)

2.2 \_\_\_\_\_ (1)

2.3 \_\_\_\_\_ (1)

2.4 \_\_\_\_\_ (1)

2.5 \_\_\_\_\_ (1)

**[5]****QUESTION 3**3.1 \_\_\_\_\_  
\_\_\_\_\_ (2)3.2 \_\_\_\_\_  
\_\_\_\_\_ (2)3.3 \_\_\_\_\_  
\_\_\_\_\_ (2)3.4 \_\_\_\_\_  
\_\_\_\_\_ (2)3.5 \_\_\_\_\_  
\_\_\_\_\_ (2)**[10]****QUESTION 4**

4.1	A	B	C	D
4.2	A	B	C	D
4.3	A	B	C	D
4.4	A	B	C	D
4.5	A	B	C	D

**(5 x 3) [15]****TOTAL SECTION A: 35**